

ESCON Module 50/4 EC-S

Servo Controller

P/N 446925

Hardware Reference

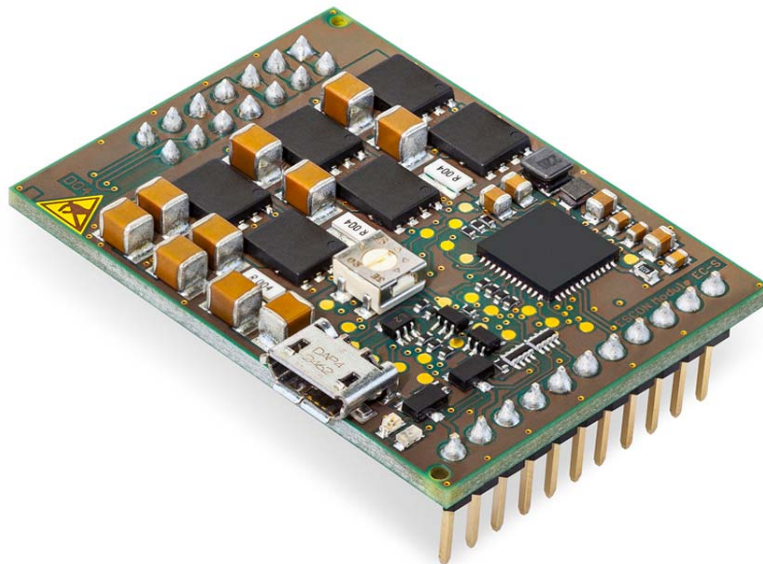

escon.maxonmotor.com

Document ID: rel8429

TABLE OF CONTENTS

1	About	3
	1.1 About this Document	3
	1.2 About the Device	5
	1.3 About the Safety Precautions	6
2	Specifications	7
	2.1 Technical Data	7
	2.2 Standards	10
3	Setup	11
	3.1 Generally applicable Rules	11
	3.2 Start-up Procedure	12
	3.3 Configuration of Power Supply	13
	3.4 Connections	14
	3.5 Potentiometer	21
	3.6 Status Indicators	22
4	Wiring	23
5	Motherboard Design Guide	25
	5.1 Requirements for Components of Third-party Suppliers	26
	5.2 Design Guidelines	29
	5.3 THT Footprint	29
	5.4 Pin Assignment	30
	5.5 Technical Data	30
	5.6 Dimensional Drawing	30
	5.7 ESCON Module Motherboard Sensorless (450237)	31
	5.8 Spare Parts	38

READ THIS FIRST

These instructions are intended for qualified technical personnel. Prior commencing with any activities ...

- you must carefully read and understand this manual and
- you must follow the instructions given therein.

The ESCON Module 50/4 EC-S is considered as partly completed machinery according to EU Directive 2006/42/EC, Article 2, Clause (g) and is intended to be incorporated into or assembled with other machinery or other partly completed machinery or equipment.

Therefore, you must not put the device into service, ...

- unless you have made completely sure that the other machinery fully complies with the EU directive's requirements!
- unless the other machinery fulfills all relevant health and safety aspects!
- unless all respective interfaces have been established and fulfill the herein stated requirements!

1 About

1.1 About this Document

1.1.1 Intended Purpose

The purpose of the present document is to familiarize you with the ESCON Module 50/4 EC-S Servo Controller. It will highlight the tasks for safe and adequate installation and/or commissioning. Follow the described instructions ...

- to avoid dangerous situations,
- to keep installation and/or commissioning time at a minimum,
- to increase reliability and service life of the described equipment.

The document contains performance data and specifications, information on fulfilled standards, details on connections and pin assignment, and wiring examples. In addition, the document also includes a Motherboard Design Guide and detailed information on the optionally available «ESCON Module Motherboard Sensorless».

1.1.2 Target Audience

The present document is intended for trained and skilled personnel. It conveys information on how to understand and fulfill the respective work and duties.

1.1.3 How to use



Take note of the following notations and codes which will be used throughout the document.

Notation	Meaning
(n)	refers to an item (such as order number, list item, etc.)
→	denotes “see”, “see also”, “take note of” or “go to”

Table 1-1 Notation used

1.1.4 Symbols & signs

In the course of the present document, the following symbols and signs will be used.

Type	Symbol	Meaning	
Safety Alert	 (typical)	DANGER	Indicates an imminent hazardous situation . If not avoided, it will result in death or serious injury .
		WARNING	Indicates a potential hazardous situation . If not avoided, it may result in death or serious injury .
		CAUTION	Indicates a probably hazardous situation or calls the attention to unsafe practices. If not avoided, it may result in injury .
Prohibited Action	 (typical)	Indicates a dangerous action. Hence, you must not!	





Type	Symbol	Meaning		
Mandatory Action	 (typical)	Indicates a mandatory action. Hence, you must!		
	Information		Requirement / Note / Remark	Indicates an activity you must perform prior to continuing, or gives information on a particular item you need to observe.
			Best Practice	Indicates advice or a recommendation on the easiest and best way to proceed.
		Material Damage	Indicates instructions on how to prevent damage to the equipment.	

Table 1-2 Symbols & Signs

1.1.5 Trademarks and Brand Names

For easier legibility, registered brand names are listed below and will not be further tagged with their respective trademark. It must be understood that the brands (the list below is not necessarily concluding) are protected by copyright and/or other intellectual property rights even if their legal trademarks are omitted in the later course of this document.

Brand Name	Trademark Owner
Littelfuse® SMD NANO2®	© Littelfuse, USA-Chicago, IL
Windows®	© Microsoft Corporation, USA-Redmond, WA

Table 1-3 Brand Names and Trademark Owners

1.1.6 Copyright

© 2018 maxon motor. All rights reserved.

The present document – including all parts thereof – is protected by copyright. Any use (including reproduction, translation, microfilming, and other means of electronic data processing) beyond the narrow restrictions of the copyright law without the prior approval of maxon motor ag, is not permitted and subject to prosecution under the applicable law.

maxon motor ag
Brünigstrasse 220
P.O.Box 263
CH-6072 Sachseln

Phone +41 41 666 15 00
Fax +41 41 666 16 50
Web www.maxonmotor.com

1.2 About the Device

The ESCON Module 50/4 EC-S is a small-sized, powerful 4-quadrant PWM servo controller for the highly efficient control of permanent magnet-activated brushless, sensorless EC motors without Hall sensors up to approximately 200 Watts.

The featured operating modes – speed control (closed loop) and speed control (open loop) – meet the highest requirements. The ESCON Module 50/4 EC-S is designed being commanded by an analog set value and features extensive analog and digital I/O functionality.

The miniaturized OEM plug-in module can be seamlessly integrated in complex customer applications. A suitable motherboard is available for the initial commissioning.

The device is designed to be configured via USB interface using the graphical user interface «ESCON Studio» for Windows PCs.

You can download the latest ESCON software version (as well as the latest edition of the documentation) from the Internet under → <http://escon.maxonmotor.com>.

1.3 About the Safety Precautions

- Make sure that you have read and understood the note “READ THIS FIRST” on page A-2!
- Do not engage in any work unless you possess the stated skills (→chapter “1.1.2 Target Audience” on page 1-3)!
- Refer to →chapter “1.1.4 Symbols & signs” on page 1-3 for explanations of the symbols used in the following!
- You must observe any regulation applicable in the country and/or at the site of implementation with regard to health and safety/accident prevention and/or environmental protection!



DANGER

High Voltage and/or Electrical Shock

Touching live wires causes death or serious injuries!

- Consider any power cable as connected to live power, unless having proven the opposite!
- Make sure that neither end of cable is connected to live power!
- Make sure that power source cannot be engaged while work is in process!
- Obey lock-out/tag-out procedures!
- Make sure to securely lock any power engaging equipment against unintentional engagement and tag it with your name!



Requirements

- Make sure that all associated devices and components are installed according to local regulations.
- Be aware that, by principle, an electronic apparatus can not be considered fail-safe. Therefore, you must make sure that any machine/apparatus has been fitted with independent monitoring and safety equipment. If the machine/apparatus should break down, if it is operated incorrectly, if the control unit breaks down or if the cables break or get disconnected, etc., the complete drive system must return – and be kept – in a safe operating mode.
- Be aware that you are not entitled to perform any repair on components supplied by maxon motor.



Electrostatic Sensitive Device (ESD)

- Make sure to wear working cloth in compliance with ESD.
- Handle device with extra care.

2 Specifications

2.1 Technical Data

ESCON Module 50/4 EC-S (446925)		
Electrical Rating	Nominal operating voltage $+V_{CC}$	10...50 VDC
	Absolute operating voltage $+V_{CC\ min}/+V_{CC\ max}$	8 VDC / 56 VDC
	Output voltage (max.)	$0.96 \times +V_{CC}$
	Output current I_{cont}/I_{max} (<30 s)	4 A / 12 A
	Pulse width modulation frequency	53.6 kHz
	Sampling rate of PI speed controller	5.36 kHz
	Max. efficiency	97%
	Max. speed EC motor	120,000 rpm (1 pole pair)
	Built-in motor choke	–
Inputs & Outputs	Analog input 1 Analog input 2	12-bit resolution; $-10...+10$ V; differential
	Analog output 1 Analog output 2	12-bit resolution ; $-4...+4$ V; referenced to GND
	Digital input 1 Digital input 2	$+2.4...+36$ VDC ($R_i = 38.5\ k\Omega$)
	Digital input/output 3 Digital input/output 4	$+2.4...+36$ VDC ($R_i = 38.5\ k\Omega$)/max. 36 VDC ($I_L < 500\ mA$)
	BEMF signals	BEMF-W1, BEMF-W2, BEMF-W3
Voltage Outputs	Auxiliary output voltage	+5 VDC ($I_L \leq 110\ mA$)
Potentiometer	Potentiometer P1 (on board)	210°; linear
Motor Connections	EC motor	Motor winding 1, Motor winding 2, Motor winding 3
Interface	USB 2.0 / USB 3.0	full speed
Status Indicators	Operation	green LED
	Error	red LED
Physical	Weight	approx. 11 g
	Dimensions (L x W x H)	43.2 x 31.8 x 12.7 mm
	Connection	Plugs into socket headers with 2.54 mm pitch

ESCON Module 50/4 EC-S (446925)			
Environmental Conditions	Temperature	Operation	-30...+45 °C
		Extended range *1)	+45...+65 °C Derating → Figure 2-1
		Storage	-40...+85 °C
	Altitude *2)	Operation	0...6'000 m MSL
		Extended range *1)	6'000...10'000 m MSL Derating → Figure 2-1
	Humidity	5...90% (condensation not permitted)	

*1) Operation within the extended range (temperature and altitude) is permitted. However, a respective derating (declination of output current I_{cont}) as to the stated values will apply.

*2) Operating altitude in meters above Mean Sea Level, MSL.

Table 2-4 Technical Data

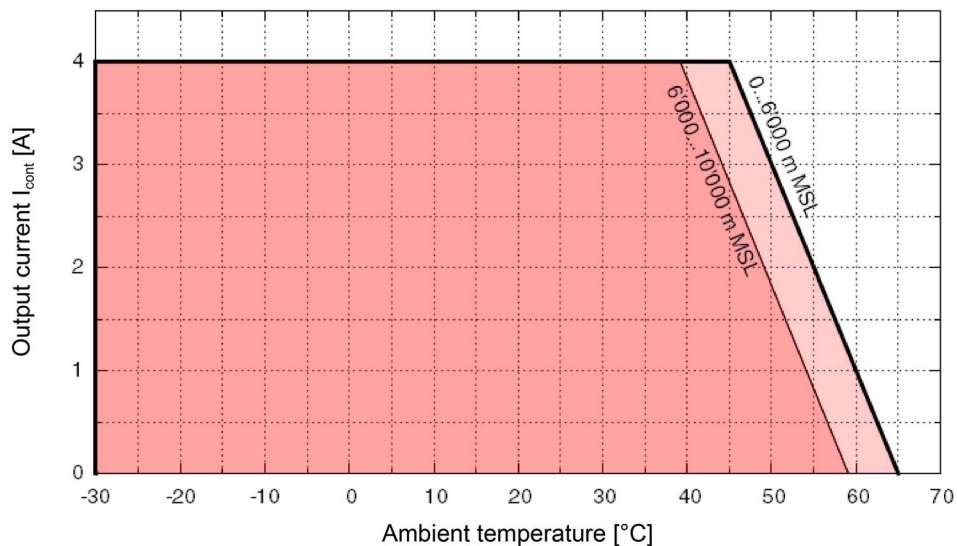

Figure 2-1 Derating Output Current

Protection functionality	Switch-off threshold	Recovery threshold
Undervoltage	7.2 V	7.4 V
Overvoltage	58 V	55 V
Overcurrent	22.5 A	—
Thermal overload	100 °C	90 °C

Table 2-5 Limitations

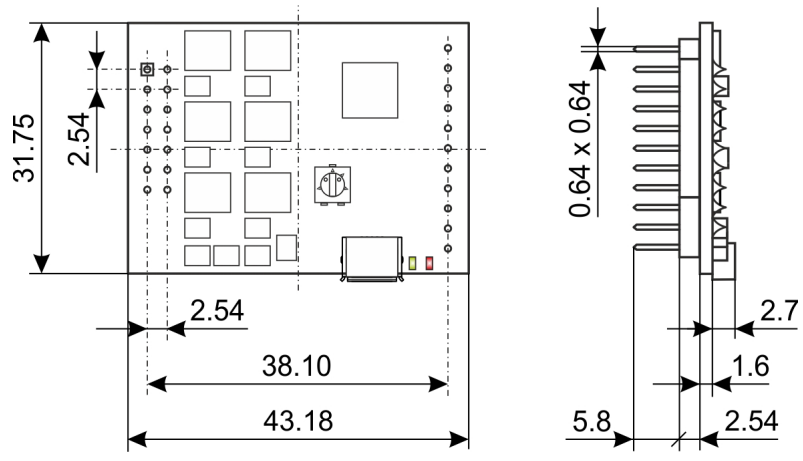

Figure 2-2 Dimensional Drawing [mm]

2.2 Standards

The described device has been successfully tested for compliance with the below listed standards. In practical terms, only the complete system (the fully operational equipment comprising all individual components, such as motor, servo controller, power supply unit, EMC filter, cabling etc.) can undergo an EMC test to ensure interference-free operation.



Important Notice

The device's compliance with the mentioned standards does not imply its compliance within the final, ready to operate setup. In order to achieve compliance of your operational system, you must perform EMC testing of the involved equipment as a whole.

Electromagnetic compatibility		
Generic standards	IEC/EN 61000-6-2	Environmental testing – Test Fc: Vibration (sinusoidal, 10...500 Hz, 20 m/s ²)
	IEC/EN 61000-6-3	Emission standard for residential, commercial and light-industrial environments
Applied standards	IEC/EN 61000-6-3 IEC/EN 55022 (CISPR22)	Radio disturbance characteristics/radio interference
	IEC/EN 61000-4-3	Radiated, radio-frequency, electromagnetic field immunity test >10 V/m
	IEC/EN 61000-4-4	Electrical fast transient/burst immunity test ±2 kV
	IEC/EN 61000-4-6	Immunity to conducted disturbances, induced by radio-frequency fields 10 Vrms

Others		
Environmental standards	IEC/EN 60068-2-6	Environmental testing – Test Fc: Vibration (sinusoidal, sinusförmig, 10...500 Hz, 20 m/s ²)
	MIL-STD-810F	Random transport (10...500 Hz up to 2.53 g _{rms})
Safety standards	UL File Number E76251; unassembled printed circuit board	
Reliability	MIL-HDBK-217F	Reliability prediction of electronic equipment Environment: Ground, benign (GB) Ambient temperature: 298 K (25 °C) Component stress: In accordance with circuit diagram and nominal power Mean Time Between Failures (MTBF): 634'498 hours

Table 2-6 Standards

3 Setup

IMPORTANT NOTICE: PREREQUISITES FOR PERMISSION TO COMMENCE INSTALLATION

The **ESCON Module 50/4 EC-S** is considered as partly completed machinery according to EU Directive 2006/42/EC, Article 2, Clause (g) and **is intended to be incorporated into or assembled with other machinery or other partly completed machinery or equipment.**

**WARNING****Risk of Injury**

Operating the device without the full compliance of the surrounding system with EU Directive 2006/42/EC may cause serious injuries!

- Do not operate the device, unless you have made completely sure that the other machinery fully complies with the EU directive's requirements!
- Do not operate the device, unless the other machinery fulfills all relevant health and safety aspects!
- Do not operate the device, unless all respective interfaces have been established and fulfill the requirements stated in this document!

3.1 Generally applicable Rules

**Maximal permitted Supply Voltage**

- Make sure that operating voltage is between 10...50 VDC.
- Supply voltages above 56 VDC, or wrong polarity will destroy the unit.
- Note that the necessary output current is depending on the load torque. Yet, the output current limits of the ESCON Module 50/4 EC-S are as follows; continuous max. 4 A / short-time (acceleration) max. 12 A.

**Hot plugging the USB interface may cause hardware damage**

If the USB interface is being hot-plugged (connecting while the power supply is on), the possibly high potential differences of the two power supplies of controller and PC/Notebook can lead to damaged hardware.

- Avoid potential differences between the power supply of controller and PC/Notebook or, if possible, balance them.
- Insert the USB connector first, then switch on the power supply of the controller.

3.2 Start-up Procedure



CAUTION

Risk of injury

During the starting operation, the motor shaft will temporarily move in both directions

- Do not take the device into operation unless all protective devices on moving parts have been completely attached and checked for proper function.
- Make sure that no loose objects are in the vicinity of any moving parts. Keep any objects which could get caught away.

A successful sensorless start-up procedure consists of two phases; the alignment phase and the acceleration phase.

ALIGNMENT PHASE

The motor shaft will be brought to and stabilized in a defined rotor position. This will be accomplished by applying a motor current ramp with a fixed step configuration without rotating stator field. During the alignment phase the motor current I_{start} rises.

ACCELERATION PHASE

A synchronous rotation of the motor with a constant acceleration α is being forced until the speed is sufficiently high for Back-EMF sampling. The motor current is limited to I_{start} .



Note

Under unfavorable conditions, the sensorless commutation principle can lead to start-up problems. Thereby, the following aspects can have a negative effect on the reliable start-up:

- high friction torques
- high moment of inertia in combination with low friction
- unsuitably defined start-up parameter

3.3 Configuration of Power Supply

Basically, any power supply may be used, provided it meets the minimal requirements stated below.

Power Supply Requirements	
Output voltage	+V _{CC} 10...50 VDC
Absolute output voltage	min. 8 VDC; max. 56 VDC
Output current	Depending on load <ul style="list-style-type: none"> • continuous max. 4 A • short-time (acceleration, <30 s) max. 12 A

- 1) Use the formula below to calculate the required voltage under load.
- 2) Choose a power supply according to the calculated voltage. Thereby consider:
 - a) During braking of the load, the power supply must be capable of buffering the recovered kinetic energy (for example, in a capacitor).
 - b) If you are using an electronically stabilized power supply, make sure that the overcurrent protection circuit is configured inoperative within the operating range.



Note

The formula already takes the following into account:

- Maximum PWM duty cycle of 96%
- Controller's max. voltage drop of 1 V @ 4 A

KNOWN VALUES:

- Operating torque M [mNm]
- Operating speed n [rpm]
- Nominal motor voltage U_N [Volt]
- Motor no-load speed at U_N, n₀ [rpm]
- Speed/torque gradient of the motor Δn/ΔM [rpm/mNm]

SOUGHT VALUE:

- Supply voltage +V_{CC} [Volt]

SOLUTION:

$$V_{CC} \geq \left[\frac{U_N}{n_0} \cdot \left(n + \frac{\Delta n}{\Delta M} \cdot M \right) \cdot \frac{1}{0.96} \right] + 1 [V]$$

3.4 Connections

The actual connection will depend on the overall configuration of your drive system and the type of motor you will be using.

Follow the description in the given order and choose the wiring diagram that best suits the components you are using. For corresponding wiring diagrams → Chapter “4 Wiring” on page 4-23.

3.4.1 Pin Assignment

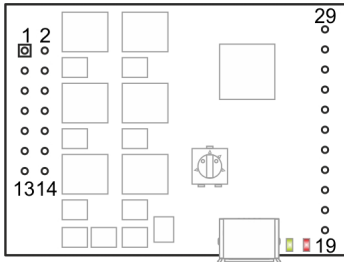

Figure 3-3 Pin Assignment

Pin	Signal	Description
1 / 2	Motor winding 1	EC motor: Winding 1
3 / 4	Motor winding 2	EC motor: Winding 2
5 / 6	Motor winding 3	EC motor: Winding 3
7 / 8	+V _{CC}	Nominal operating voltage (+10...+50 VDC)
9 / 10	Power_GND GND	Ground of operating voltage Ground
11	+5 VDC	Auxiliary output voltage (+5 VDC; ≤110 mA)
12	BEMF-W3	Back-EMF signal of winding 3
13	BEMF-W1	Back-EMF signal of winding 1
14	BEMF-W2	Back-EMF signal of winding 2
19	DigIN/DigOUT4	Digital input/output 4
20	DigIN/DigOUT3	Digital input/output 3
21	DigIN2	Digital input 2
22	DigIN1	Digital input 1
23	GND	Ground
24	AnOUT2	Analog output 2
25	AnOUT1	Analog output 1
26	AnIN2-	Analog input 2, negative signal
27	AnIN2+	Analog input 2, positive signal
28	AnIN1-	Analog input 1, negative signal
29	AnIN1+	Analog input 1, positive signal

Table 3-7 Pin Assignment & Wiring

3.4.2 Back-EMF Signals

**Best Practice**

- Make sure that all three Back-EMF signal leads are of identical length and that they are being routed in parallel. Thereby, keep the leads as short as possible.
- The Back-EMF signal leads must be connected with the corresponding motor winding terminals.
- If no motor output filter is used, the Back-EMF signal leads may be connected directly to the motor winding terminals:
 - Pin [13] BEMF-W1 with pins [1/2] motor winding 1
 - Pin [14] BEMF-W2 with pins [3/4] motor winding 2
 - Pin [12] BEMF-W3 with pins [5/6] motor winding 3
- If a motor output filter is used, the Back-EMF signal leads should be connected to the filter's motor exit side.
- For further details → "Motherboard Design Guide" on page 5-25.

Input voltage	0...50 VDC
Max. input voltage	±100 VDC

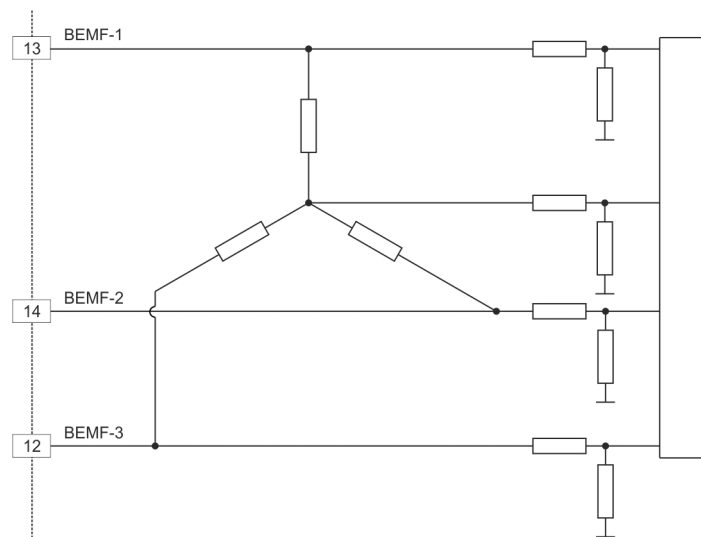
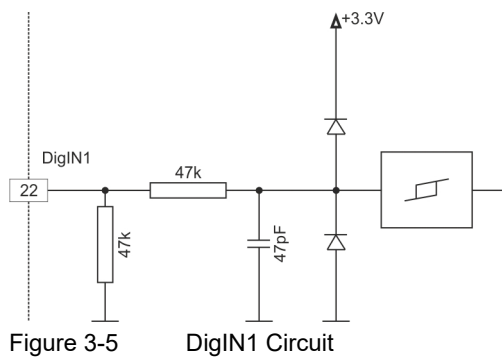

Figure 3-4 Back-EMF Signal Circuit

3.4.3 Digital I/Os

3.4.3.1 Digital Input 1

Input voltage	0...36 VDC
Max. input voltage	+36 VDC/-36 VDC
Logic 0	typically <1.0 V
Logic 1	typically >2.4 V
Input resistance	typically 47 k Ω (<3.3 V) typically 38.5 k Ω (@ 5 V) typically 25.5 k Ω (@ 24 V)
Input current at logic 1	typically 130 μ A @ +5 VDC
Switching delay	<8 ms
PWM frequency range	25 Hz...5 kHz
PWM duty cycle range (resolution)	10...90% (0.1%)
RC Servo cycle duration	3...30 ms
RC Servo pulse length	1...2 ms



3.4.3.2 Digital Input 2

Input voltage	0...36 VDC
Max. input voltage	+36 VDC/-36 VDC
Logic 0	typically <1.0 V
Logic 1	typically >2.4 V
Input resistance	typically 47 kΩ (<3.3 V) typically 38.5 kΩ (@ 5 V) typically 25.5 kΩ (@ 24 V)
Input current at logic 1	typically 130 μA @ +5 VDC
Switching delay	<8 ms

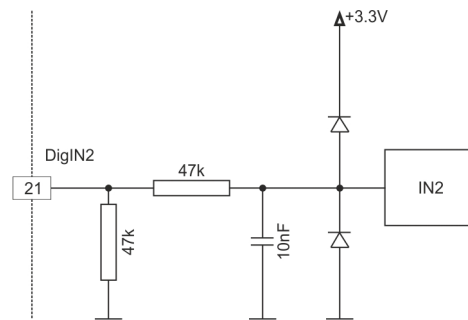

Figure 3-6 DigIN2 Circuit

3.4.3.3 Digital Inputs/Outputs 3 and 4

DigIN	
Input voltage	0...36 VDC
Max. input voltage	+36 VDC
Logic 0	typically <1.0 V
Logic 1	typically >2.4 V
Input resistance	typically 47 kΩ (<3.3 V) typically 38.5 kΩ (@ 5 V) typically 25.5 kΩ (@ 24 V)
Input current at logic 1	typically 130 μA @ +5 VDC
Switching delay	<8 ms

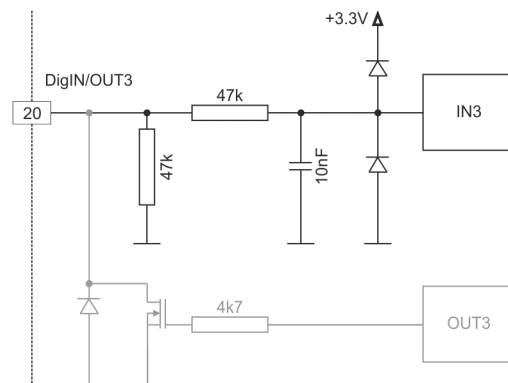

Figure 3-7 DigIN3 Circuit (analogously valid also for DigIN4)

DigOUT	
Max. input voltage	+36 VDC
Max. load current	500 mA
Max. voltage drop	0.5 V @ 500 mA
Max. load inductance	100 mH @ 24 VDC; 500 mA

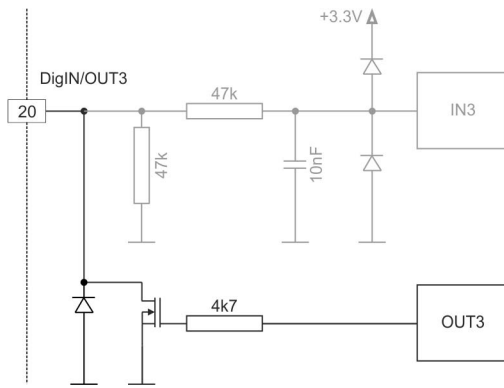

Figure 3-8 DigOUT3 Circuit (analogously valid also for DigOUT4)

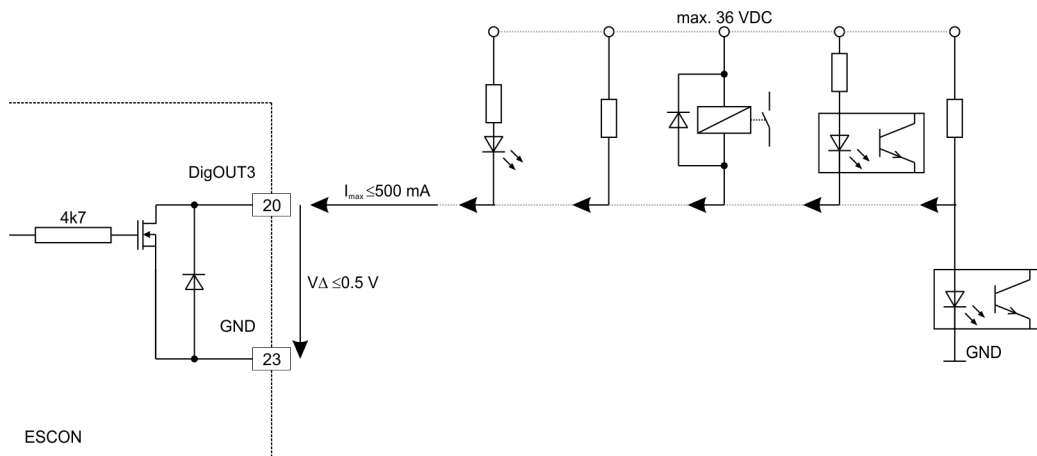

Figure 3-9 DigOUT3 Wiring Examples (analogously valid also for DigOUT4)

3.4.4 Analog I/Os

3.4.4.1 Analog Inputs 1 and 2

Input voltage	-10...+10 VDC (differential)
Max. input voltage	+24 VDC/-24 VDC
Common mode voltage	-5...+10 VDC (referenced to GND)
Input resistance	80 kΩ (differential) 65 kΩ (referenced to GND)
A/D converter	12-bit
Resolution	5.64 mV
Bandwidth	10 kHz

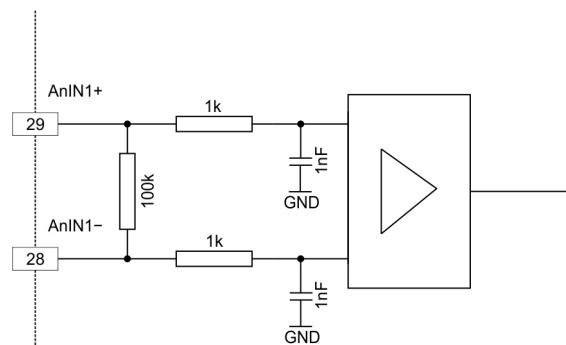

Figure 3-10 AnIN1 Circuit (analogously valid also for AnIN2)

3.4.4.2 Analog Outputs 1 and 2

Output voltage	-4...+4 VDC
D/A converter	12-bit
Resolution	2.42 mV
Refresh rate	AnOUT1: 26.8 kHz AnOUT2: 5.4 kHz
Analog bandwidth of output amplifier	50 kHz
Max. capacitive load	300 nF Note: The rate of the increase is limited in proportion to the capacitive load (e.g. 5 V/ms @300 nF).
Max. output current limit	1 mA

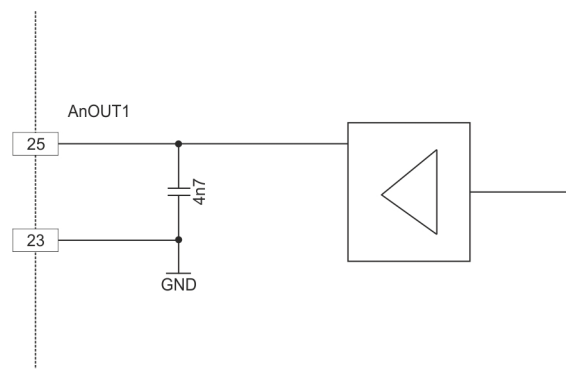

Figure 3-11 AnOUT1 Circuit (analogously valid also for AnOUT2)

3.4.5 USB (J7)



Hot plugging the USB interface may cause hardware damage

If the USB interface is being hot-plugged (connecting while the power supply is on), the possibly high potential differences of the two power supplies of controller and PC/Notebook can lead to damaged hardware.

- Avoid potential differences between the power supply of controller and PC/Notebook or, if possible, balance them.
- Insert the USB connector first, then switch on the power supply of the controller.

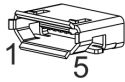

Figure 3-12 USB Socket J7



Note

Column “Head B” (→Table 3-8) refers to USB terminals of your PC.

J7 & Head A Pin	Head B Pin	Signal	Description
1	1	V_{BUS}	USB BUS supply voltage input +5 VDC
2	2	D-	USB Data- (twisted pair with Data+)
3	3	D+	USB Data+ (twisted pair with Data-)
4	–	ID	not connected
5	4	GND	USB ground

Table 3-8 USB Socket J7 – Pin Assignment & Cabling

USB Type A - micro B Cable (403968)	
<div style="display: flex; justify-content: space-between;"> <div style="border: 1px solid black; padding: 2px; font-weight: bold; width: 20px; height: 20px; display: flex; align-items: center; justify-content: center;">A</div> <div style="border: 1px solid black; padding: 2px; font-weight: bold; width: 20px; height: 20px; display: flex; align-items: center; justify-content: center;">B</div> </div>	
Cable cross-section	According to USB 2.0 / USB 3.0 specification
Length	1.5 m
Head A	USB type “micro B”, male
Head B	USB type “A”, male

Table 3-9 USB Type A - micro B Cable

USB standard	USB 2.0 / USB 3.0 (full speed)
Max. bus operating voltage	+5.25 VDC
Typical input current	60 mA
Max. DC data input voltage	-0.5...+3.8 VDC

3.5 Potentiometer

POTENTIOMETER P1

Adjustment angle	210°
Type	Linear

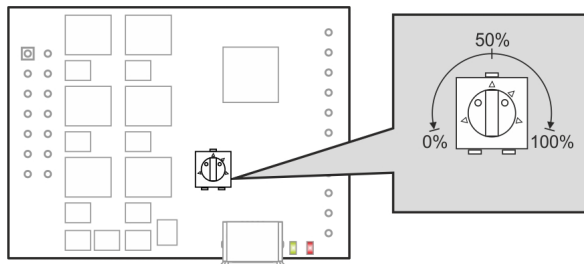

Figure 3-13 Potentiometer – Location & Adjustment Range

3.6 Status Indicators

Light-emitting diodes (LEDs) indicate the actual operating status (green) and possible errors (red).

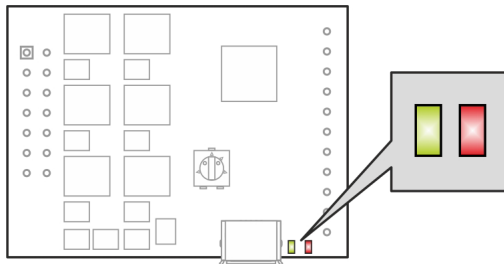

Figure 3-14 LEDs – Location

LED		Status/Error	
Green	Red		
off	off	INIT	
slow	off	DISABLE	
fast	off	STARTUP SENSORLESS	
on	off	ENABLE	
2x	off	STOPPING; STOP STANDSTILL	
3x	off	SET VALUE SENSORLESS TOO SMALL	
off	1x	ERROR	<ul style="list-style-type: none"> • +Vcc Overvoltage Error • +Vcc Undervoltage Error • +5 VDC Undervoltage Error
off	2x	ERROR	<ul style="list-style-type: none"> • Thermal Overload Error • Overcurrent Error • Power Stage Protection Error • Internal Hardware Error
off	4x	ERROR	• PWM Set Value Input out of Range Error
off	5x	ERROR	<ul style="list-style-type: none"> • Sensorless error: Motor blocked • Sensorless error: Start-up failed
off	on	ERROR	<ul style="list-style-type: none"> • Auto Tuning Identification Error • Internal Software Error

Table 3-10 LEDs – Interpretation of Condition

4 Wiring

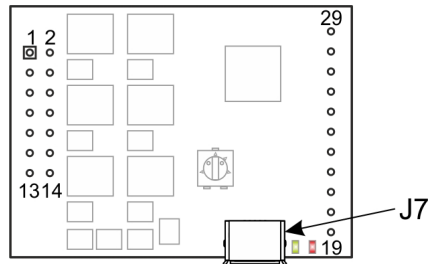



Figure 4-15 Interfaces – Designations and Location



Note

The subsequent diagrams feature this symbol:

-  Ground safety earth connection (optional)

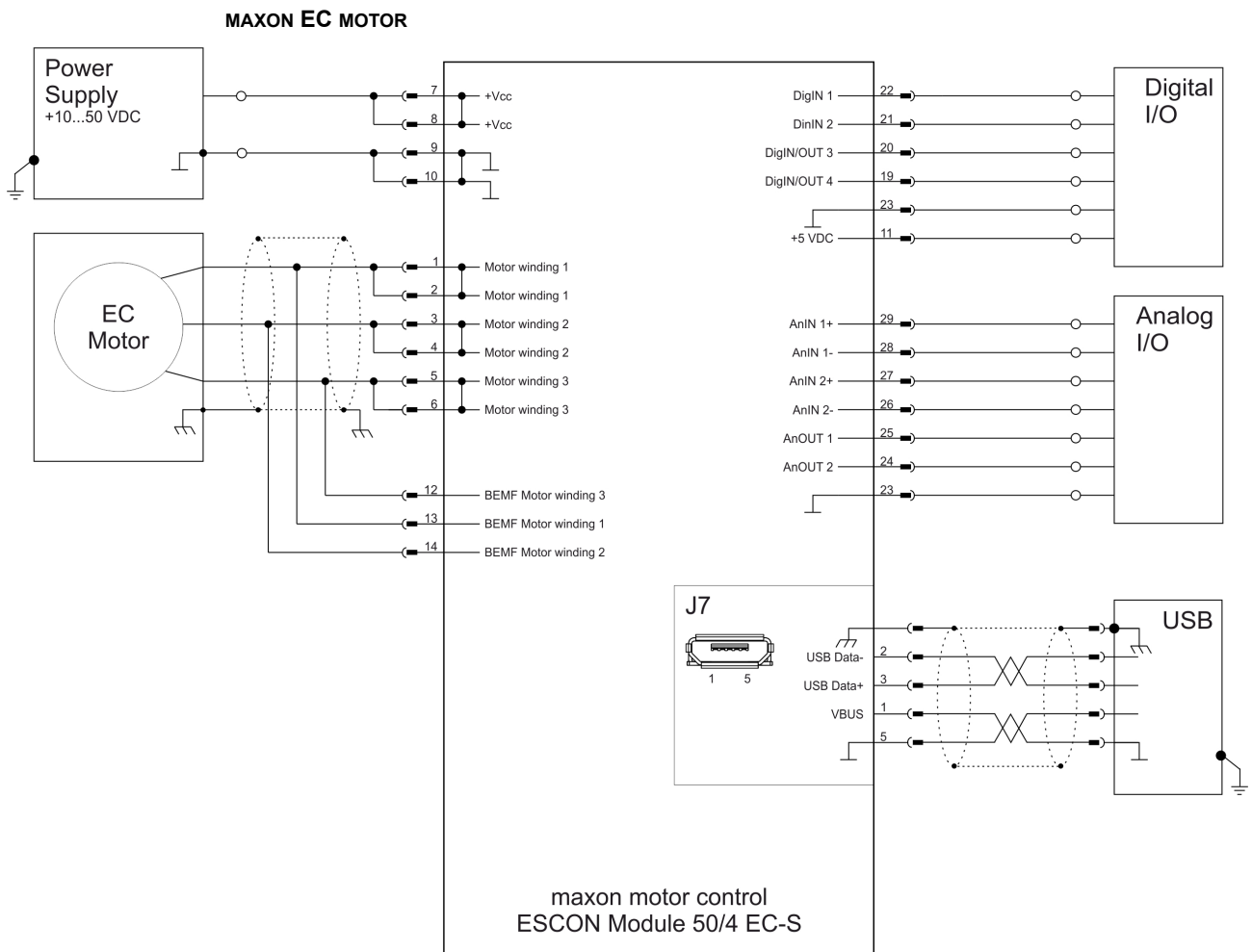

Figure 4-16 maxon EC motor

••page intentionally left blank••

5 Motherboard Design Guide

The following provides helpful information on integrating the ESCON Module 50/4 EC-S on a printed circuit board. The «Motherboard Design Guide» contains recommendations for the layout of the motherboard and specifies external components that may be required, pin assignments, and connection examples.



CAUTION

Dangerous Action

Errors in implementing the Design can result in serious Injury!

- *Only proceed if you are skilled in electronics design!*
- *Designing a printed circuit board requires special skills and knowledge and may only be performed by experienced electronic developers!*
- *This quick guide is only intended as an aid, does not make any claim to completeness, and will not automatically result in a functional component!*



Bring in additional Support:

If you are not trained in the design and development of printed circuit boards, you will need additional support for this point.

maxon motor will be happy to provide you with a quote for designing and manufacturing a motherboard for your specific application.

5.1 Requirements for Components of Third-party Suppliers

5.1.1 Socket Headers

The ESCON Module 50/4 EC-S's implementation with pin headers permits mounting in two different ways. The module can either be plugged onto a socket header (→ Table 5-11) or be directly soldered to a printed circuit board.

5.1.2 Supply Voltage

To protect the ESCON Module 50/4 EC-S, we recommend using an external circuit breaker, a TVS diode, and a capacitor in the voltage supply cable. In this regard, please note the following recommendations:

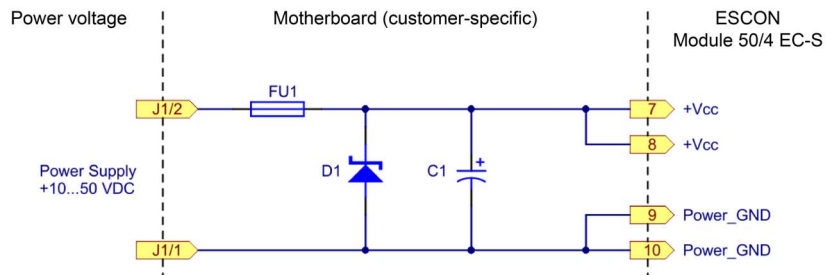

Figure 5-17 Wiring of Voltage Supply Cable

INPUT FUSE (FU1)

An input fuse (FU1) is necessary in order to provide reverse polarity protection. Together with a unipolar TVS diode (D1), this prevents current from flowing in the wrong direction.

TVS DIODE (D1)

To protect against overvoltage resulting from voltage transients or brake energy feedback, we recommend connecting a TVS (transient voltage suppressor) diode (D1) to the voltage supply cable.

CAPACITOR (C1)

The function of the ESCON Module 50/4 EC-S does not necessarily require the use of an external capacitor (C1). To further reduce voltage ripple and feedback currents, an electrolytic capacitor can be connected to the voltage supply cable.

5.1.3 Motor Cables / Motor Chokes

The ESCON Module 50/4 EC-S is not equipped with internal motor chokes.

The majority of motors and applications do not require additional chokes. However, in the case of high supply voltage with very low terminal inductance, the ripple of the motor current can reach an unacceptably high value. This causes the motor to heat up unnecessarily and causes instable control behavior. The minimum terminal inductance required per phase can be calculated using the following formula:

$$L_{phase} \geq \frac{1}{2} \cdot \left(\frac{V_{cc}}{3 \cdot f_{PWM} \cdot I_N} - (0.3 \cdot L_{motor}) \right)$$

$L_{phase}[H]$	Additional external inductance per phase
$V_{cc}[V]$	Operating voltage +V _{cc}
$f_{PWM}[Hz]$	Switching frequency of the power stage = 53 600 Hz
$I_N[A]$	Nominal current of the motor (→line 6 in the maxon catalog)
$L_{motor}[H]$	Terminal inductance of the motor (→line 11 in the maxon catalog)

If the result of the calculation is negative, no additional chokes are necessary. Nevertheless, the use of chokes in combination with additional filter components can be useful to reduce the emission of electromagnetic interference.

An additional choke must feature electromagnetic shielding, a high saturation current, minimal losses, and a nominal current greater than the continuous current of the motor. The below wiring example refers to an additional inductance of 22 µH. If a different additional inductance is required, also the filter components must be adapted accordingly. Should you need further help with the filter design, contact maxon Support at →<http://support.maxonmotor.com>.

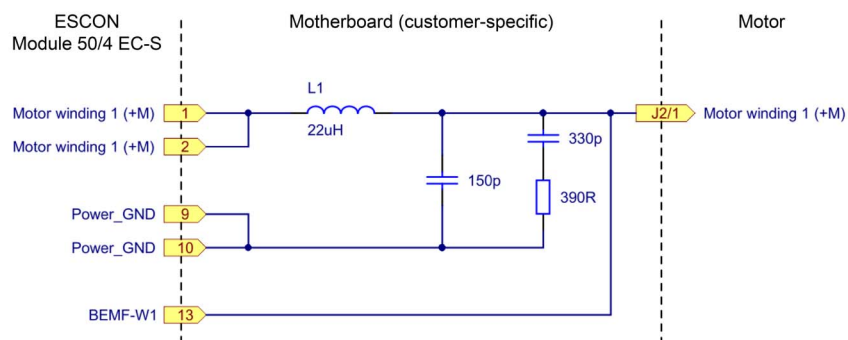

Figure 5-18 Wiring of Motor Winding 1 (analogously valid also for Motor Windings 2 & 3)

5.1.4 Recommended Components and Manufacturers

Recommended components					
Socket Header	Straight socket header, pluggable with 0.64 x 0.64 mm pin headers, 2.54 mm pitch, 3 A, contact material: gold				
	<table border="1" style="width: 100%; border-collapse: collapse;"> <tr> <td style="width: 30%; background-color: #fff9c4;">7 poles, 2 rows</td> <td style="background-color: #fff9c4;">Preci-Dip (803-87-014-10-005101) Würth (613 014 218 21) E-tec (BL2-014-S842-55)</td> </tr> <tr> <td style="background-color: #fff9c4;">11 poles, 1 row</td> <td style="background-color: #fff9c4;">Preci-Dip (801-87-011-10-005101) Würth (613 011 118 21) E-tec (BL1-011-S842-55)</td> </tr> </table>	7 poles, 2 rows	Preci-Dip (803-87-014-10-005101) Würth (613 014 218 21) E-tec (BL2-014-S842-55)	11 poles, 1 row	Preci-Dip (801-87-011-10-005101) Würth (613 011 118 21) E-tec (BL1-011-S842-55)
	7 poles, 2 rows	Preci-Dip (803-87-014-10-005101) Würth (613 014 218 21) E-tec (BL2-014-S842-55)			
11 poles, 1 row	Preci-Dip (801-87-011-10-005101) Würth (613 011 118 21) E-tec (BL1-011-S842-55)				
Littelfuse 157 series, fuse holder incl. SMD NANO2 Fuse 10 A very fast-acting, 26.46 A ² sec (0157010.DR)					
TVS Diode D1	<ul style="list-style-type: none"> • Vishay (SMBJ54A) U_R = 54 V, U_{BR} = 60.0...66.3 V @ 1 mA, U_C = 87.1 V @ 6.9 A • Diotec (P6SMBJ54A) U_R = 54 V, U_{BR} = 60.0...66.6 V @ 1 mA, U_C = 87.1 V @ 6.9 A 				
Capacitor C1	<ul style="list-style-type: none"> • Panasonic (EEUFC1J221S) Rated voltage 63 V, capacitance 220 µF, ripple current 1285 mA • Rubycon (63ZL220M10X23) Rated voltage 63 V, capacitance 220 µF, ripple current 1120 mA • Nichicon (UPM1J221MHD) Rated voltage 63 V, capacitance 220 µF, ripple current 1300 mA 				
Motor Cable Motor Choke	<ul style="list-style-type: none"> • Würth Elektronik WE-PD-XXL (7447709220) L_N = 22 µH, R_{DC} = 23.3 mΩ, I_{DC} = 5.3 A, I_{sat} = 6.5 A, shielded • Coiltronics (DR127-220) L_N = 22 µH, R_{DC} = 39.1 mΩ, I_{DC} = 4.0 A, I_{sat} = 7.6 A, shielded • Würth Elektronik WE-PD-XXL (7447709150) L_N = 15 µH, R_{DC} = 21 mΩ, I_{DC} = 6.5 A, I_{sat} = 8.0 A, shielded • Sumida (CDRH129RNP-150MC) L_N = 15 µH, R_{DC} = 16 mΩ, I_{DC} = 6.0 A, I_{sat} >6.0 A, shielded • Coiltronics (DR127-150) L_N = 15 µH, R_{DC} = 25 mΩ, I_{DC} = 5.0 A, I_{sat} = 9.7 A, shielded • Bourns (SRR1280-150M) L_N = 15 µH, R_{DC} = 28 mΩ, I_{DC} = 5.2 A, I_{sat} >5.2 A, shielded • Würth Elektronik WE-PD-XL (7447701115) L_N = 15 µH, R_{DC} = 24 mΩ, I_{DC} = 5.0 A, I_{sat} = 6.0 A, shielded • Sumida (CDR127/LDNP-150M) L_N = 15 µH, R_{DC} = 20 mΩ, I_{DC} = 5.7 A, I_{sat} >5.7 A, shielded 				

Table 5-11 Motherboard Design Guide – Recommended Components

5.2 Design Guidelines

The following instructions are intended to serve as an aid for designing an application-specific motherboard and ensuring the correct and reliable integration of the ESCON Module 50/4 EC-S.

5.2.1 Ground

All ground connections (GND) should be internally connected to the ESCON Module 50/4 EC-S (equal potential). It is customary to equip the motherboard with a ground plane. All ground connections should be connected to the voltage supply ground via wide conductive tracks.

Pin	Signal	Description
9	Power_GND GND	Ground of operating voltage Ground
10	Power_GND GND	Ground of operating voltage Ground
23	GND	Ground

Table 5-12 Motherboard Design Guide – Grounding

If an earth potential is in place or required, the ground plane should be connected to the earth potential via one or more capacitors. The use of ceramic capacitors with 100 nF and 100 V is recommended.

5.2.2 Layout

Guidelines for the layout of the motherboard:

- Connector pins [7] and [8] +V_{CC} operating voltage:
The pins should be connected to the fuse via wide conductive tracks.
- Connector pins [9], [10] and [23] ground:
All pins should be connected with the ground of the operating voltage via wide conductive tracks.
- The width of the conductive track and the copper coating thickness of the conductors for supply voltage and motor depend on the current required for the application. A minimum width of 75 mil is recommended for the track and a minimum thickness of 35 µm for the copper coating.

5.3 THT Footprint

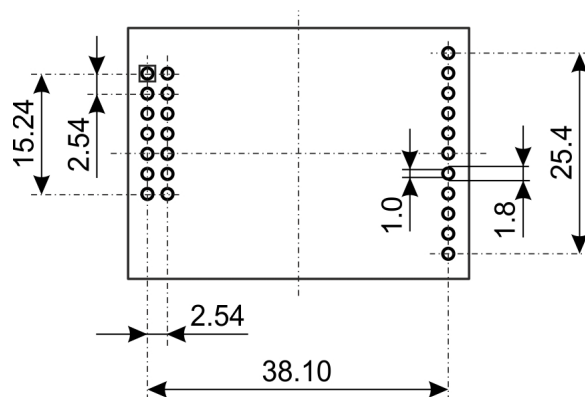

Figure 5-19 THT Footprint [mm] – View from above

5.4 Pin Assignment

For detailed specifications →chapter “3.4 Connections” on page 3-14.

5.5 Technical Data

For detailed specifications →chapter “2 Specifications” on page 2-7.

5.6 Dimensional Drawing

For the dimensional drawing →Figure 2-2 on page 2-9.

5.7 ESCON Module Motherboard Sensorless (450237)

The ESCON Module Motherboard Sensorless (subsequently named ESCON Module MoBo) is available as an alternative to developing an own motherboard. All required connections are already in place and designed as screw-type terminals.

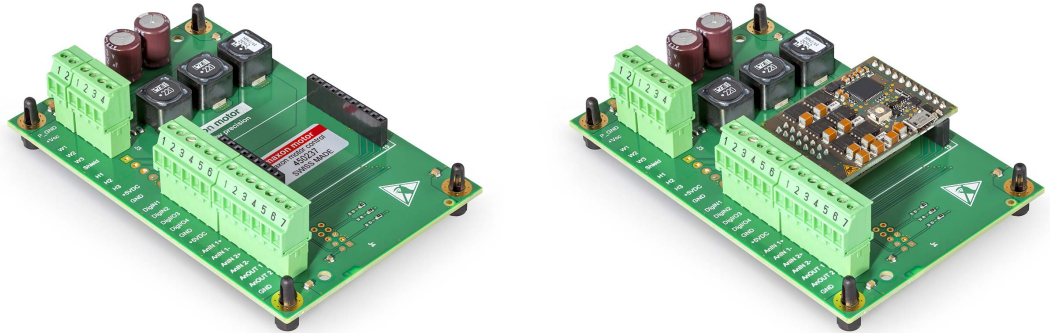

Figure 5-20 ESCON Module MoBo (left), with mounted ESCON Module 50/4 EC-S (right)

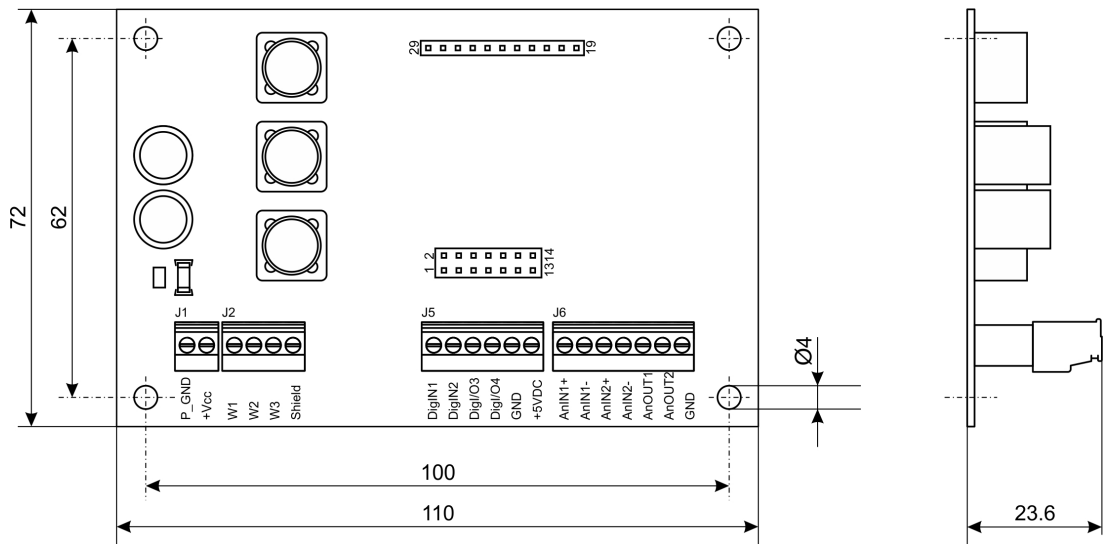

Figure 5-21 ESCON Module MoBo – Dimensional Drawing [mm]

5.7.1 Assembly

The ESCON Module MoBo is designed to easily be screw-mounted or integrated into standard rail systems. For ordering information for the components required →Figure 5-22 (only for illustrative purposes) and →Table 5-13.

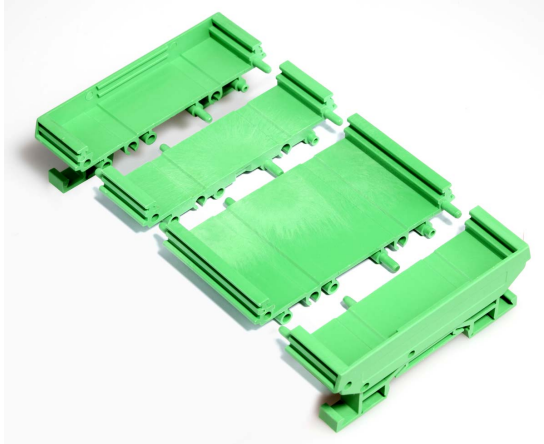

Figure 5-22 ESCON Module MoBo – Mounting on DIN Rail

Specification / Accessories	
Adapter for DIN rail	PHOENIX CONTACT 2 x panel mounting base element 11.25 mm UMK-SE11.25-1 (2970442) 2 x base element 45 mm UMK-BE45 (2970015) 2 x foot element UMK-FE (2970031)
	CamdenBoss 2 x end section with foot 22.5 mm (CIME/M/SEF2250S) 1 x base element 22.5 mm (CIME/M/BE2250SS) 1 x base element 45 mm (CIME/M/BE4500SS)

Table 5-13 ESCON Module MoBo, mounting on DIN Rail – Specification & Accessories

5.7.2 Connections



Note

The USB interface is located directly at the ESCON Module 50/4 EC-S.

5.7.2.1 Power Supply (J1)

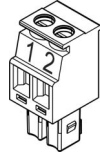

Figure 5-23 ESCON Module MoBo – Power Plug J1

J1 Pin	Signal	Description
1	Power_GND	Ground of operating voltage
2	+V _{CC}	Nominal operating voltage (+10...+50 VDC)

Table 5-14 ESCON Module MoBo – Power Plug J1 – Pin Assignment

Specification / Accessories	
Type	Pluggable screw-type terminal block, 2 poles, 3.5 mm pitch
Suitable cables	0.14...1.5 mm ² multi-core, AWG 28-14 0.14...1.5 mm ² single wire, AWG 28-14

Table 5-15 ESCON Module MoBo – Power Plug J1 – Specification & Accessories

5.7.2.2 Motor (J2)

The servo controller is set to drive brushless, sensorless EC motors (without Hall sensors).

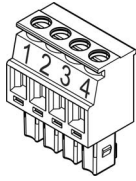

Figure 5-24 ESCON Module MoBo – Motor Plug J2

J2 Pin	Signal	Description
1	Motor winding 1	EC motor: Winding 1
2	Motor winding 2	EC motor: Winding 2
3	Motor winding 3	EC motor: Winding 3
4	Motor shield	Cable shield

Table 5-16 ESCON Module MoBo – Motor Plug J2 – Pin Assignment for maxon EC motor (brushless)

Specification / Accessories	
Type	Pluggable screw-type terminal block, 4 poles, 3.5 mm pitch
Suitable cables	0.14...1.5 mm ² multi-core, AWG 28-14 0.14...1.5 mm ² single wire, AWG 28-14

Table 5-17 ESCON Module MoBo – Motor Plug J2 – Specification & Accessories

5.7.2.3 Digital I/Os (J5)

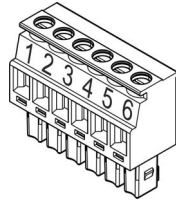

Figure 5-25 ESCON Module MoBo – Digital I/Os Plug J5

J5 Pin	Signal	Description
1	DigIN1	Digital input 1
2	DigIN2	Digital input 2
3	DigIN/DigOUT3	Digital input/output 3
4	DigIN/DigOUT4	Digital input/output 4
5	GND	Ground
6	+5 VDC	Auxiliary output voltage (+5 VDC; ≤110 mA)

Table 5-18 ESCON Module MoBo – Digital I/Os Plug J5 – Pin Assignment

Specification / Accessories	
Type	Pluggable screw-type terminal block, 6 poles, 3.5 mm pitch
Suitable cables	0.14...1.5 mm ² multi-core, AWG 28-14 0.14...1.5 mm ² single wire, AWG 28-14

Table 5-19 ESCON Module MoBo – Digital I/Os Plug J5 – Specification & Accessories

5.7.2.4 Analog I/Os (J6)

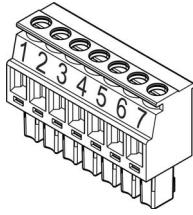

Figure 5-26 ESCON Module MoBo – Analog I/Os Plug J6

J6 Pin	Signal	Description
1	AnIN1+	Analog input 1, positive signal
2	AnIN1-	Analog input 1, negative signal
3	AnIN2+	Analog input 2, positive signal
4	AnIN2-	Analog input 2, negative signal
5	AnOUT1	Analog output 1
6	AnOUT2	Analog output 2
7	GND	Ground

Table 5-20 ESCON Module MoBo – Analog I/Os Plug J6 – Pin Assignment

Specification / Accessories	
Type	Pluggable screw-type terminal block, 7 poles, 3.5 mm pitch
Suitable cables	0.14...1.5 mm ² multi-core, AWG 28-14 0.14...1.5 mm ² single wire, AWG 28-14

Table 5-21 ESCON Module MoBo – Analog I/Os Plug J6 – Specification & Accessories

5.7.3 Wiring



Note

The USB interface is located directly at the ESCON Module 50/4 EC-S.



Note

The subsequent diagrams feature this symbol:

- Ground safety earth connection (optional)

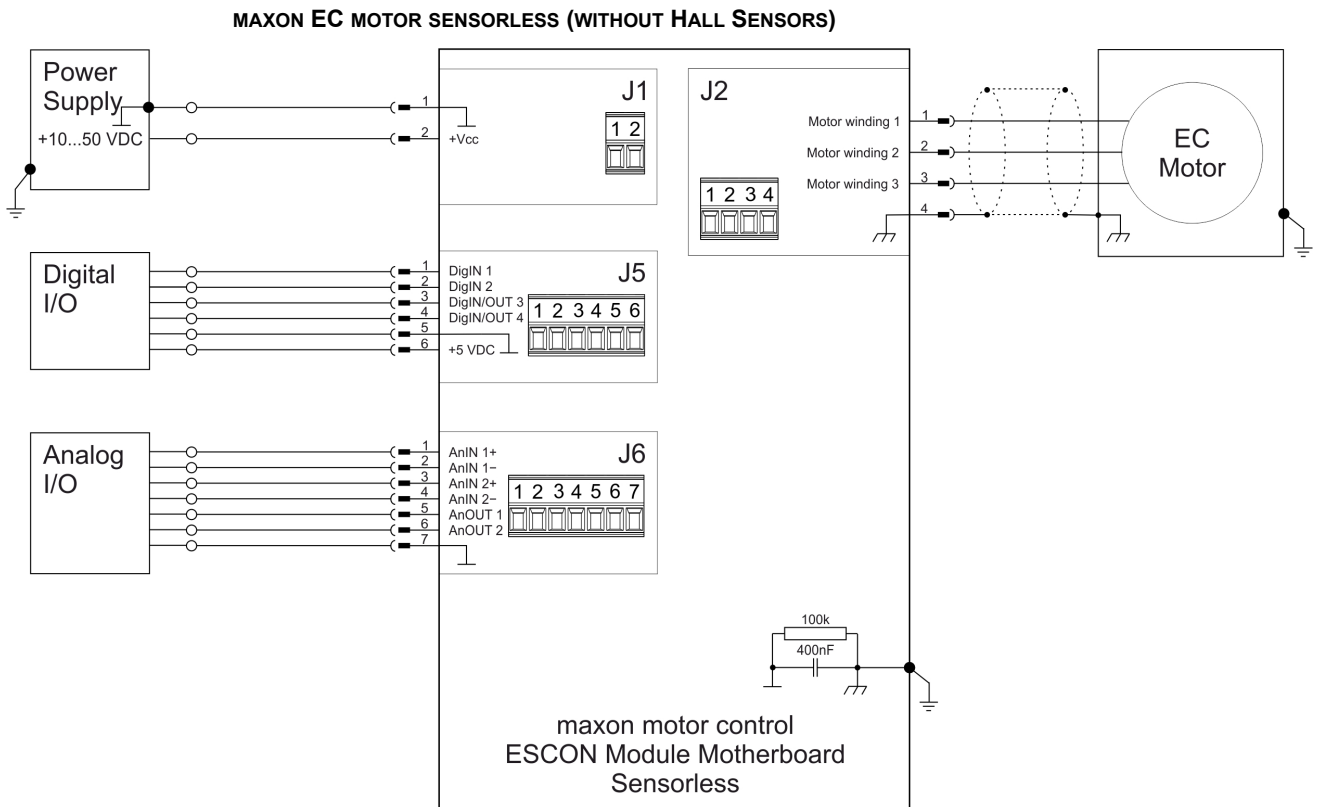

Figure 5-27 ESCON Module MoBo – maxon EC motor sensorless without Hall Sensors (J2)

5.8 Spare Parts

Order number	Description
444144	2-pole pluggable screw-type terminal block, 3.5 mm pitch, labeled 1...2
444145	4-pole pluggable screw-type terminal block, 3.5 mm pitch, labeled 1...4
444147	6-pole pluggable screw-type terminal block, 3.5 mm pitch, labeled 1...6
444148	7-pole pluggable screw-type terminal block, 3.5 mm pitch, labeled 1...7

Table 5-22 Spare Parts List

LIST OF FIGURES

Figure 2-1 Derating Output Current8

Figure 2-2 Dimensional Drawing [mm]9

Figure 3-3 Pin Assignment14

Figure 3-4 Back-EMF Signal Circuit15

Figure 3-5 DigIN1 Circuit16

Figure 3-6 DigIN2 Circuit17

Figure 3-7 DigIN3 Circuit (analogously valid also for DigIN4)17

Figure 3-8 DigOUT3 Circuit (analogously valid also for DigOUT4)18

Figure 3-9 DigOUT3 Wiring Examples (analogously valid also for DigOUT4)18

Figure 3-10 AnIN1 Circuit (analogously valid also for AnIN2)19

Figure 3-11 AnOUT1 Circuit (analogously valid also for AnOUT2)19

Figure 3-12 USB Socket J720

Figure 3-13 Potentiometer – Location & Adjustment Range21

Figure 3-14 LEDs – Location22

Figure 4-15 Interfaces – Designations and Location23

Figure 4-16 maxon EC motor23

Figure 5-17 Wiring of Voltage Supply Cable.26

Figure 5-18 Wiring of Motor Winding 1 (analogously valid also for Motor Windings 2 & 3)27

Figure 5-19 THT Footprint [mm] – View from above29

Figure 5-20 ESCON Module MoBo (left), with mounted ESCON Module 50/4 EC-S (right)31

Figure 5-21 ESCON Module MoBo – Dimensional Drawing [mm]31

Figure 5-22 ESCON Module MoBo – Mounting on DIN Rail32

Figure 5-23 ESCON Module MoBo – Power Plug J133

Figure 5-24 ESCON Module MoBo – Motor Plug J234

Figure 5-25 ESCON Module MoBo – Digital I/Os Plug J535

Figure 5-26 ESCON Module MoBo – Analog I/Os Plug J6.36

Figure 5-27 ESCON Module MoBo – maxon EC motor sensorless without Hall Sensors (J2)37

LIST OF TABLES

Table 1-1	Notation used	3
Table 1-2	Symbols & Signs.	4
Table 1-3	Brand Names and Trademark Owners	4
Table 2-4	Technical Data	8
Table 2-5	Limitations	8
Table 2-6	Standards	10
Table 3-7	Pin Assignment & Wiring	14
Table 3-8	USB Socket J7 – Pin Assignment & Cabling	20
Table 3-9	USB Type A - micro B Cable	20
Table 3-10	LEDs – Interpretation of Condition	22
Table 5-11	Motherboard Design Guide – Recommended Components	28
Table 5-12	Motherboard Design Guide – Grounding	29
Table 5-13	ESCON Module MoBo, mounting on DIN Rail – Specification & Accessories	32
Table 5-14	ESCON Module MoBo – Power Plug J1 – Pin Assignment	33
Table 5-15	ESCON Module MoBo – Power Plug J1 – Specification & Accessories	33
Table 5-16	ESCON Module MoBo – Motor Plug J2 – Pin Assignment for maxon EC motor (brushless).	34
Table 5-17	ESCON Module MoBo – Motor Plug J2 – Specification & Accessories	34
Table 5-18	ESCON Module MoBo – Digital I/Os Plug J5 – Pin Assignment	35
Table 5-19	ESCON Module MoBo – Digital I/Os Plug J5 – Specification & Accessories	35
Table 5-20	ESCON Module MoBo – Analog I/Os Plug J6 – Pin Assignment	36
Table 5-21	ESCON Module MoBo – Analog I/Os Plug J6 – Specification & Accessories	36
Table 5-22	Spare Parts List	38

INDEX**A**

acceleration phase (sensorless start-up) 12
additionally applicable regulations 6
alignment phase (sensorless start-up) 12
analog inputs 19
applicable EU directive 11
assignment of the connections 14

B

Back-EMF signals 15

C

cables (prefab)
 USB Type A - micro B Cable 20
country-specific regulations 6

D

digital inputs 16, 17

E

error display 22
ESD 6
EU directive, applicable 11

H

how to
 calculate required supply voltage 13
 interpret icons (and signs) used in the document 3
 start-up a sensorless motor 12
 support for designing the motherboard 25

I

incorporation into surrounding system 11
informatory signs 4
intended purpose
 of the device 5
 of this document 3
interfaces, location and designation 23

L

LEDs 22

M

mandatory action signs 4
MoBo (ESCON Module Motherboard Sensorless) 31

N

notations used 3

O

operating license 11
operating status, display 22
order numbers
 403968 20
 438725 7
 444144 38
 444145 38
 444147 38
 444148 38
 450237 31

P

performance data 7
pin assignment 14
potentiometer 21
precautions 6
prerequisites prior installation 11
prohibitive signs 3
purpose
 of the device 5

R

regulations, additionally applicable 6

S

safety alerts 3
safety first! 6
signs used 3
sockets
 J1 33
 J2 34
 J5 35
 J6 36
 J7 20
standards, fulfilled 10
start-up procedure, sensorless 12
status display 22
status LEDs 22
supply voltage, required 13
symbols used 3

T

technical data 7

U

USB interface 20

© 2018 maxon motor. All rights reserved.

The present document – including all parts thereof – is protected by copyright. Any use (including reproduction, translation, microfilming, and other means of electronic data processing) beyond the narrow restrictions of the copyright law is not permitted without the prior approval of maxon motor ag and will be subject to prosecution under the applicable law.

maxon motor ag

Brünigstrasse 220
P.O.Box 263
CH-6072 Sachseln
Switzerland

Phone +41 41 666 15 00

Fax +41 41 666 16 50

www.maxonmotor.com